

**STRAIGHT JACK CRIMP OR SOLDER TYPE
CABLE 5/50 D**

R125.240.000
SERIES SMA

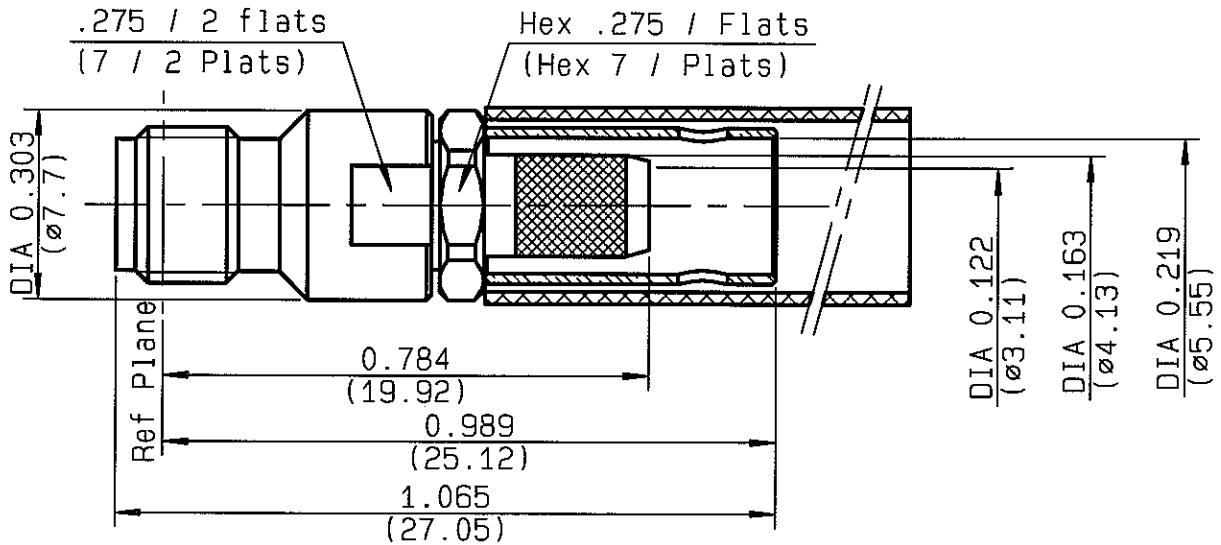

NOMINAL IMPEDANCE	50 Ω
FREQUENCY RANGE	0-12.4 GHz
TEMPERATURE RATING	-65/+165 °C
V.S.W.R	1.15 + .01 x F(GHz)Maxi
RF INSERTION LOSS	0.06 \sqrt{F} (GHz) dB Maxi
VOLTAGE RATING	335 Veff Maxi
DIELECTRIC WITHSTANDING VOLTAGE	1000 Veff Mini
INSULATION RESISTANCE	5000 M Ω Mini
HERMETIC SEAL	NA Atm.cm ³ /s
LEAKAGE (pressurized only)	NA
MECHANICAL DURABILITY	500 Cycles
WEIGHT	gr
SPECIFICATION	

CABLES : **KX 23**
RG 142
RG 142 FTX
RG 223
RG 400

OTHERS CHARACTERISTICS

CABLE RETENTION	204 N Mini
CENTER CONTACT RETENTION	
Axial force - mating end	27 N Mini
Axial force - opposite end	27 N Mini
Torque	NA cm.N Mini
RECOMMENDED TORQUES	
Mating	NA cm.N
Panel nut	NA cm.N
Clamp nut	100 cm.N

CONNECTOR PARTS	MATERIALS	FINISH	(all values are given in micrometers)
BODY	STAINLESS STEEL	GOLD 0.5 OVER NICKEL 2	
OUTER CONTACT			
CENTER CONTACT	BERYLLIUM COPPER	GOLD 1.3 OVER NICKEL 2	
INSULATOR	PTFE	-	
GASKET		-	
OTHERS PIECES	BRASS	GOLD 0.2 OVER NICKEL 2	

GUILLOMIN

ISSUE **0622E** CREATION DATE **23/03/1990** FILE PART-NUMBER



The information given here is subject to change without notice. Design changes may be in order to improve the product.

Connect to the future



R125.240.000

ISSUE **9910D01** SERIES **SMA**

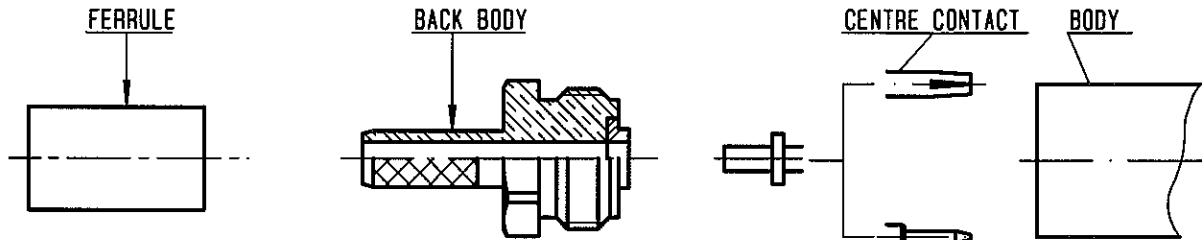

①

Slide onto the cable the ferrule .
Strip the cable .
-
-

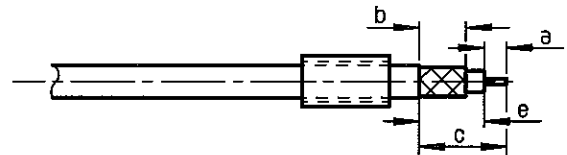

Stripping	a	b	c	d	e
inch	0.138	0.276	0.531	0	0.394
mm	3.5	7	13.5		10

②

Fan the braid .
Slide the back body between dielectric and braid .
Slide ferrule over the braid .
(In direction F)

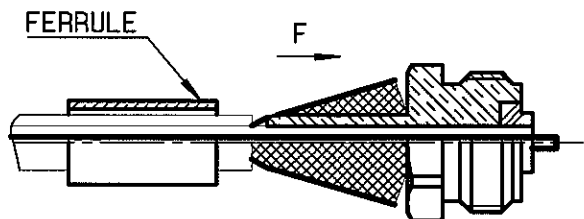

③

Crimp the ferrule with crimping tool R 282 223 000 (Hex. : .213) or crimping tool R 282 293 000 (M22520/5-01) + dies R 282 235 011 (M22520/5-11)
Slide on the centre contact until it bottoms against insulator .
Solder the centre contact .
Mount the front insulator .

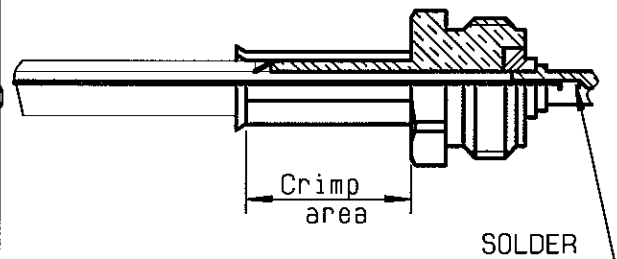

④

Screw sub-assembly into the connector body .
(recommended coupling torque 80 a 120 N.cm)
7.08 to 10.62 in.lb

